

# Stainless Steel Hybrid Pallet Jack

Your New Warehouse Worker

## Features

- Lithium Battery
- Upright Driving
- Powerful & Portable
- Minimum Maintenance
- Ergonomic Handle Design



Fork



Easier entrance/ exit design for pallet (single wheel available)

Key Switch



Integral design of key switch and emergency stop

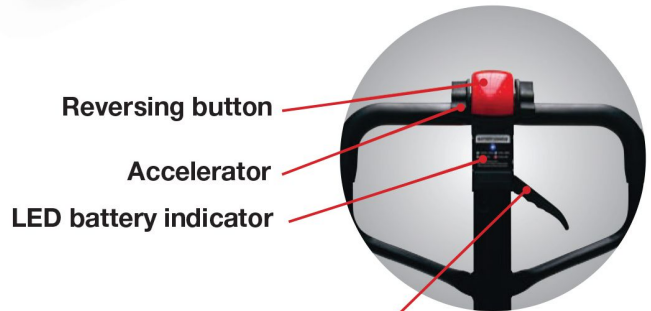

Reversing button

Accelerator

LED battery indicator

Lowering releasing lever

Manual Brake Release



Just use like hand pallet truck

Portable Lithium Battery



2 years warranty | 3 kg / 6.6 lbs  
20 seconds quick change

Hybrid Plus



Powered driving + Powered lifting

Quick Charge



2 hours (option)

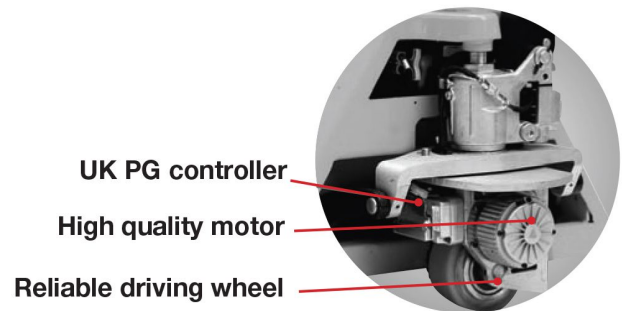

UK PG controller

High quality motor

Reliable driving wheel

# Stainless Steel Hybrid Pallet Jack

Your New Warehouse Worker

## Drawings

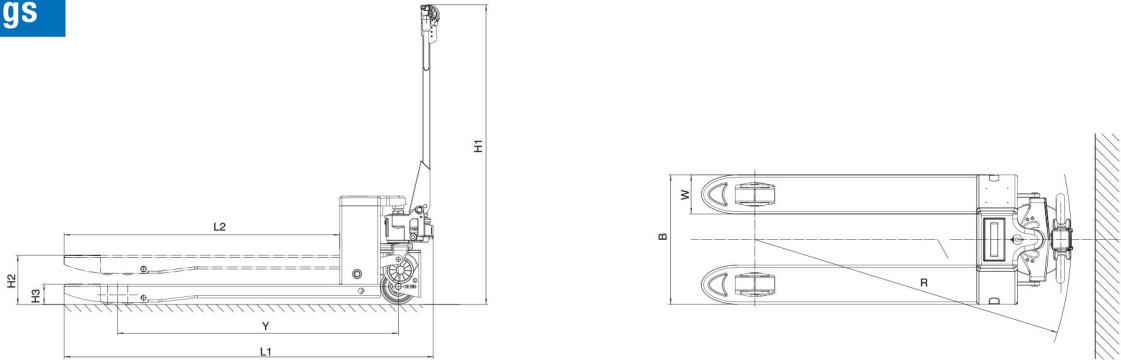

## Specifications

		Metric	Imperial
Model		xxxx	
Operator type		Walkie	Walkie
Load Capacity	Q	1500kg	3000lbs
Load Center	C	600mm	24"
Wheelbase	Y	1170mm/1240mm	46"/48.8"
Service Weight		125kg	275lbs
Overall Height	H1	1250mm	49"
Lift Height	H2	200mm	8"
Fork Height (Lowered)	H3	85mm	3.3"
Overall Length	L1	1540mm/1610mm	60.6"/63.4"
Overall Width	B	540mm/680mm	21"/27"
Fork Size	L2	540x1150mm/680x1220mm	21"x45"/27"x48"
Travel Speed (laden/unladen)		4/4.5kmh	2.5/2.8mph
Max. Gradeability (laden/unladen)	%	3%/20%	3%/20%
Battery Voltage/ Capacity	V/Ah	24V/20Ah Li-Battery	24V/20Ah Li-Battery
Turning Radius	R	1320mm/1390mm	52"/55"